



**Dimensions (mm)**

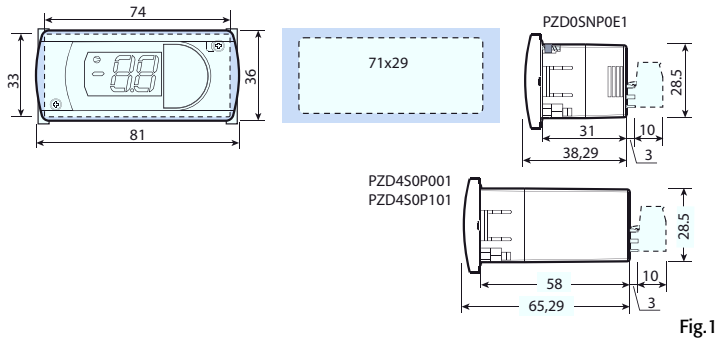

Fig.1

**Panel mounting**

Front (with 2 screws  $\varnothing$  2,5x12 mm)

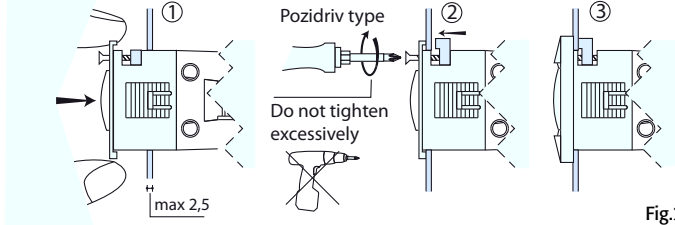

Fig.2

Rear (with 2 quick-fit side brackets)

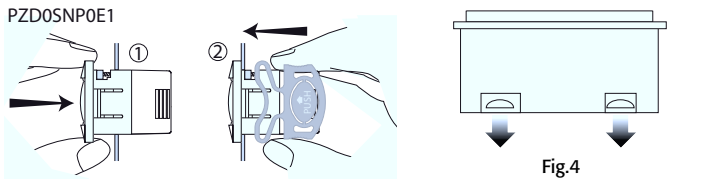

Fig.4

PZD450P001, PZD450P101

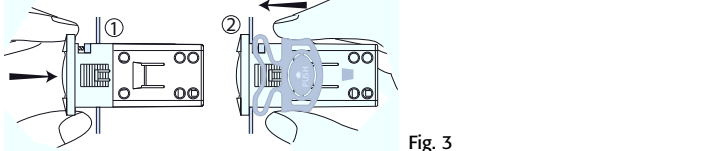

Fig.3

**Electrical connections**

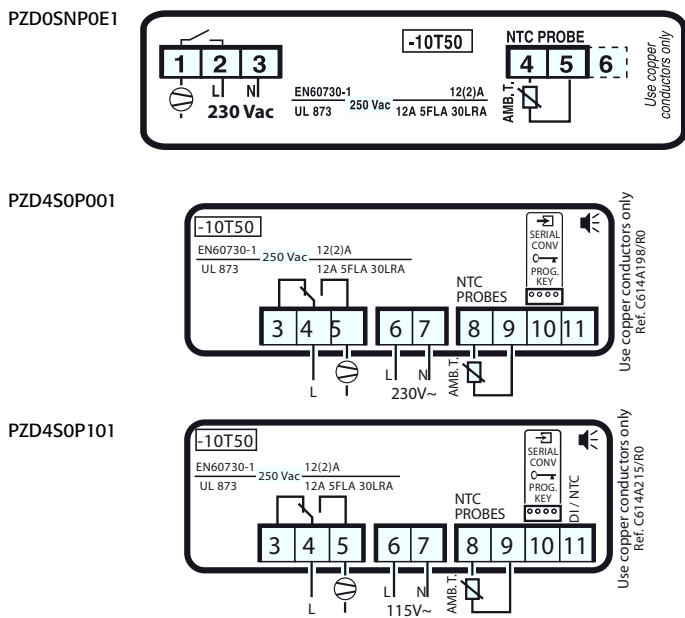

Fig.5

**Description**

PIEZ\* represents a range of electronic microprocessor controllers with LED display developed for the management of refrigerating units, display cabinets and showcases; are designed for the management of static refrigerating units (no fan on the evaporator) operating at temperatures above 0°C.

**Technical specifications**

- Electronic controllers for normal temperature static refrigeration units
- Power supply 115Vac or 230Vac
- Ambient probe NTC
- Compressor relay 16A

**Display and functions**

During normal operation, the controller displays the value of the temperature read by probe. In addition, the display has LED that indicate the activation of the control functions (see Tab. 1), while the 3 buttons can be used to activate/deactivate some of the functions (see Tab. 2).

**Compressor LED signals**

icon	function	normal operation			start up
		ON	OFF	blink	
	compressor status	on	off	ON request in progress	ON

Tab. 1

**Table of functions activated by the buttons**

button	normal operation	start up
	up ON/OFF more than 3 s: toggle ON/OFF	-
	down defrost more than 3 s: start/stop defrost	for 1 s display firmware vers. code
	set mute - 1 s.: display/set the set point - more than 3 s: access parameter setting menu (enter password '22')	for 1 s RESET current EY set

Tab. 2

**Setting the setpoint (desired temperature)**

Step	Action	Effect	Meaning
1	Keep SET button pressed for 2 s	After 1 sec currently setpoint value will flash on display	It's regulation setpoint currently active
2	Press UP or DOWN buttons	Setpoint value will change	Set desired value
3	Press SET button	Controller will visualize temperature read by probes again	setpoint is modified and saved

Tab. 3

**Accessing and setting the parameters**

Step	Action	Effect	Meaning
1	Keep SET button pressed for 3 s	After 3 s display will visualize "PS"	Password is requested
2	Press SET button again	Display will visualize "0" blinking	
3	Press UP or DOWN button	Visualized value on display will change	Insert password "22"
4	Press SET button	After 5 s the first parameter, "/5", will be visualized on display	It's the name of the first parameter
5	Press UP or DOWN button	Parameter list will be scrolled on display (refer to Table of parameters)	Select desired parameter
6	Press SET button	Display will visualize value of the selected parameter	It's the currently parameter value
7	Press UP or DOWN button	Parameter value visualized on display will change	Set desired value
8	Press SET button	Display will visualize parameter name again	<b>Attention:</b> parameters updating is not yet active
9	Repeat steps 5, 6, 7 and 8 for all desired parameters		
10	Keep SET button pressed for 5 s	Controller will visualize temperature read by probes again	<b>Attention:</b> now parameters updating will be active

Tab. 4

## Table of parameters

	Parameter	Min.	Max.	Def.	UOM
PS	PASSWORD	0	99	22	-
/	<b>PROBE PARAMETERS</b>				
/5	Select °C / °F ( 0 = °C; 1 = °F)	0	1	0	-
/6	Disable decimal point (1 = disabled)	0	1	0	-
/C1	Probe calibration (OFFSET)	-50.0	50.0	0.0	°C/°F
r	<b>CONTROL PARAMETERS</b>				
St	Setpoint (control temperature)	-50.0	90.0	3.0	°C/°F
rd	Control differential (hysteresis)	0.0	19.0	2.0	°C/°F
c	<b>COMPRESSOR PARAMETERS</b>				
c0	Comp. and fan start delay after start-up	0	100	0	min
c1	Min. time between successive comp. starts	0	100	1	min
c4	Compressor safety (duty setting)	0	100	15	min
d	<b>DEFROST PARAMETERS</b>				
d0	Type of defrost (0 and 1= defrost by temperature; 2, 3 and 4= defrost by time)	0	4	2	-
d1	Interval between defrosts	0	199	6	h/min
dP	Max. or effective defrost duration	1	199	20	min/s
d4	Defrost when the instrument is switched on (1= activated)	0	1	0	-
d6	Disable temperature display during defrost (1= display disabled)	0	1	1	-
A	<b>ALARM PARAMETERS</b>				
A0	Alarm differential	-20.0	20.0	-2.0	°C/°F
AL	Low temperature alarm threshold/deviation	-50.0	250.0	-5.0	°C/°F
AH	High temperature alarm threshold/deviation	-50.0	250.0	15.0	°C/°F
Ad	Low and high temperature alarm delay	0	199	0	min
H	<b>OTHER SETTINGS</b>				
H2	Enable keypad 0= keypad disabled 1= keypad enabled 2= keypad enabled except for ON/OFF function	0	2	1	-
EY	Restore the Default settings	0	1	0	-

Tab. 5

## Table of alarms

Alarm code	Description	Parameters involved
E0	probe 1 error= control	-
LO	low temperature alarm	[AL] [Ad]
HI	high temperature alarm	[AH] [Ad]
EE	unit parameter error	-
EF	operating parameter error	-
dF	defrost running	[d6=0]
Pd	defrost awaiting execution	-

Tab. 6

## How to restore the Default settings (refer to table of parameters in this sheet)

- 1) Access parameter EY (entering password 22 and scroll parameter list).
- 2) Select the desired configuration:
  - EY = 0 → No changes;
  - EY = 1 → Restore of default settings (refer to Table of parameters in this sheet);
- 3) Exit the setting procedure (holding SET button for more than 3 s).
- 4) Power off the device and then power it on again while holding SET button.
- 5) The display shows "CE" to indicate that the configuration has been restored.

## Switching the device ON/OFF

Press UP for more than 3 s. The control and defrost algorithms are now disabled and the instrument displays the message "OFF" alternating with the temperature read by the set probe.

## Manual defrost

Press DOWN for more than 3 s (the defrost starts only if the temperature conditions are valid).

## Continuous cycle

Press UP and DOWN together for more than 3 s.

## Technical specifications

power supply	115 Vac +10 / -15% 50/60 Hz 230 Vac -10% +15% 50/60 Hz
rated power	3 W
input	NTC probe
relay output	16 A relay UL: 12 A resistive 5 FLA, 30 LRA 240 Vac 30,000 cycles EN60730-1: 12(2)A or 10(4)A (N.O. only) 250 Vac 100000 cycles;
type of probe	Std CAREL NTC 10 KΩ at 25 °C
power supply/ relay output connector	- screw terminals pitch 5mm for cables with cross-sect. from 0.5 mm <sup>2</sup> to 1.5 mm <sup>2</sup> ; 12 A max;
probe connector	screw terminals: - 2-pin pitch 5mm for models with 1 probe (cable cross-section from 0.5 mm <sup>2</sup> to 1.5 mm <sup>2</sup> ); 12 A max;
assembly	using screws from the front or with brackets at the rear
display	LED display, 2 digits plus sign, decimal point and compressor icon
keypad	3 buttons with membrane
operating conditions	-10T50 °C - humidity <90% rH non-condensing
storage conditions	-20T70 °C - humidity <90% rH non-condensing
range of measurement	-50T90 °C (-58T194 °F) - resolution 0.1 °C/°F
front panel index of protection	panel installation with IP65 type 1
case	plastic terminal, 81x36x38 mm
classification according to protection against electric shock	Class II
environmental pollution	II
PTI of the insulating material	250 V
period of stress across the insulating parts	long
category of resistance to heat and fire	category D (UL94 - V0)
immunity against voltage surges	category 1
type of action and disconnection	micro-disconnection 1C
no. of relay automatic operating cycles	EN60730-1: 100,000 cycles UL: 30,000 cycles (250 Vac)
software class and structure	Class A
cleaning the instrument	Only use neutral detergents and water
cable max. length	serial: 1 km probes: 30 m relay: 10 m

Tab. 7

**Note:** do not run the power cable less than 3 cm from the bottom part of the device or from the probes; **for the connections only use copper wires.**

## Safety standards

compliant with the relevant European standards. Installation precautions:

- the connection cables must guarantee insulation up to 90 °C;
- ensure a space of at least 10 mm between the case and the nearby conductive parts;
- digital and analogue input connections less than 30 m away; adopt suitable measures for separating the cables so as to ensure compliance with the immunity standards;

Secure the connection cables of the outputs so as to avoid contact with very low voltage parts.

## IMPORTANT WARNINGS

The CAREL product is a state-of-the-art device, whose operation is specified in the technical documentation supplied with the product or can be downloaded, even prior to purchase, from the website [www.carel.com](http://www.carel.com). The customer (manufacturer, developer or installer of the final equipment) accepts all liability and risk relating to the configuration of the product in order to reach the expected results in relation to the specific final installation and/or equipment. The failure to complete such phase, which is required/indicated in the user manual, may cause the final product to malfunction; CAREL accepts no liability in such cases. The customer must use the product only in the manner described in the documentation relating to the product. The liability of CAREL in relation to its products is specified in the CAREL general contract conditions, available on the website [www.carel.com](http://www.carel.com) and/or by specific agreements with customers.



**WARNING:** separate as much as possible the probe and digital input signal cables from the cables carrying inductive loads and power cables to avoid possible electromagnetic disturbance. Never run power cables (including the electrical panel wiring) and signal cables in the same conduits.



## Disposal of the product

The appliance (or the product) must be disposed of separately in accordance with the local waste disposal legislation in force.

CAREL reserves the right to modify the features of its products without prior notice.

# CAREL

CAREL INDUSTRIES HQS  
Via dell'Industria, 11 - 35020 Brugine - Padova (Italy)  
Tel. (+39) 0499716611 - Fax (+39) 0499716600 - <http://www.carel.com> - e-mail: [carel@carel.com](mailto:carel@carel.com)

+050004121 - rel. 1.1 - 28.07.2011



LEGGI E CONSERVA QUESTE ISTRUZIONI  
READ AND SAVE THESE INSTRUCTIONS

NO POWER & SIGNAL CABLES TOGETHER  
READ CAREFULLY IN THE TEXT!

**Dimensions (mm)**

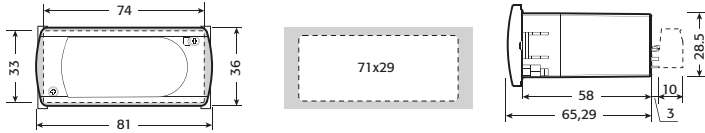

Fig.1

**Panel mounting**

Front (with 2 screws  $\varnothing$  2,5x12 mm)

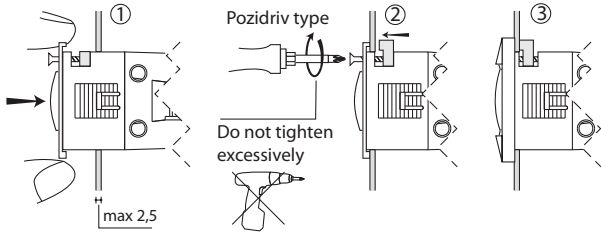

Fig.2

Rear (with 2 quick-fit side brackets)

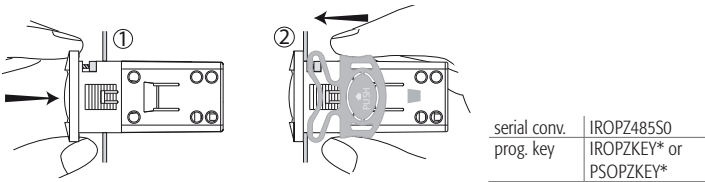

Fig. 3

**Electrical connections**

PZDOC0P001

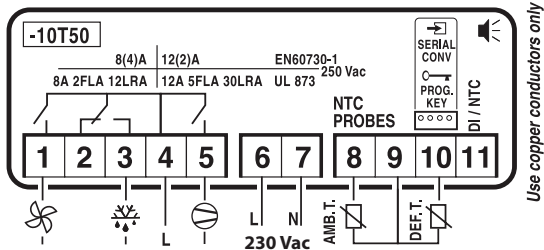
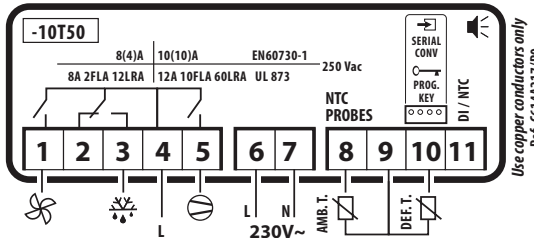

Fig. 4

PZD4C0H001



PZD4C0H101

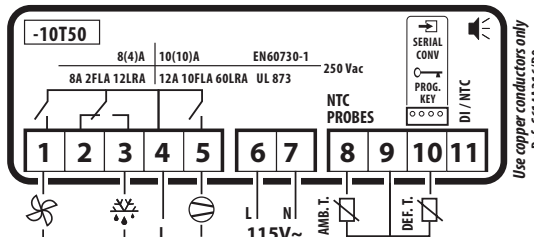

Fig. 5

**Description**

PJEZ\* represent a range of electronic microprocessor controllers with LED display developed for the management of refrigerating units, display cabinets and showcases.

**Technical specifications**

- Electronic controllers for low temperature ventilated refrigeration units
- Power supply 115 or 230Vac
- Ambient probe NTC
- Compressor relay 16A
- Defrost relay 8A
- Evaporator fan relay 8A

**Display and functions**

During normal operation, the controller displays the temperature read by probe 1. In addition, the display has LEDs that indicate the activation of the control functions (see Table 1), while the 3 buttons can be used to activate/deactivate some of the functions (see Table 2).

**LEDs and associated functions**

icon	function	normal operation			start up
		ON	OFF	blink	
	compressor	on	off	request	ON
	fan	on	off	request	ON
	defrost	on	off	request	ON
	alarm	all	no alarm	-	ON

Tab. 1

**Table of functions activated by the buttons**

button	normal operation		start up
	pressing the button alone	pressed together	
	more than 3 s: toggle ON/OFF	Pressed together start/stop continuous cycle	-
	more than 3 s: start/stop defrost		for 1 s display firmware vers. code
	- 1 s.: display/set the setpoint - more than 3 s: access parameter setting menu (enter password '22') - mute audible alarm (buzzer)	-	for 1 s RESET current EZY set

Tab. 2

**Setting the setpoint (desired temperature)**

Step	Action	Effect	Meaning
1	Keep SET button pressed for 2 s	After 1 sec currently setpoint value will flash on display	It's regulation setpoint currently active
2	Press UP or DOWN buttons	Setpoint value will change	Set desired value
3	Press SET button	Controller will visualize temperature read by probes again	Setpoint is modified and saved

Tab. 3

**Accessing and setting the parameters**

Step	Action	Effect	Meaning
1	Keep SET button pressed for 3 s	After 3 sec display will visualize "PS"	Password is requested
2	Press SET button again	Display will visualize "0" blinking	
3	Press UP or DOWN button	Visualized value on display will change	Insert password "22"
4	Press SET button	After 5 sec the first parameter, "/5", will be visualized on display	It's the name of the first parameter
5	Press UP or DOWN button	Parameter list will be scrolled on display (refer to Table of parameters)	Select desired parameter
6	Press SET button	Display will visualize value of the selected parameter	It's the currently parameter value
7	Press UP or DOWN button	Parameter value visualized on display will change	Set desired value
8	Press SET button	Display will visualize parameter name again	<b>Attention:</b> parameters updating is not yet active
9	Repeat steps 5, 6, 7 and 8 for all desired parameters		
10	Keep SET button pressed for 5 s	Controller will visualize temperature read by probes again	<b>Attention:</b> now parameters updating will be active

Tab. 4

## Table of parameters

	Parameter	Min.	Max.	Def.	UOM
PS	PASSWORD	0	200	22	-
/	<b>PROBE PARAMETERS</b>				
/5	Select °C / °F (0 = °C; 1 = °F)	0	1	0	-
/6	Disable decimal point (1 disabled)	0	1	0	-
/C1	Probe calibration	-50.0	50.0	0.0	°C/°F
/C2	Probe 2 calibration	-50.0	50.0	0.0	°C/°F
r	<b>CONTROL PARAMETERS</b>				
St	Control temperature	-50.0	90.0	-18.0	°C/°F
rd	Control differential (hysteresis)	0.0	19.0	2.0	°C/°F
c	<b>COMPRESSOR PARAMETERS</b>				
c0	Comp. and fan start delay after start-up	0	100	0	min
c1	Min. time between successive comp. starts	0	100	1	min
c4	Compressor safety (duty setting)	0	100	15	min
d	<b>DEFROST PARAMETERS</b>				
d0	Type of defrost (0= heater; 1= hot gas; 2= heater by time; 3= hot gas by time; 4= heater by time with temp. cont.)	0	4	0	-
dI	Interval between two defrosts	0	199	6	h/min
dt	End defrost temperature	50.0	130.0	8	°C/°F
dP	Max. or effective defrost duration	1	199	25	min/s
d4	Defrost when the instrument is switched on (1= activated)	0	1	0	-
d6	Disable temperature display during defrost (1= display disabled)	0	1	1	-
dd	Dripping time after defrost	0	15	1	min
d/	Defrost probe reading	-	-	-	°C/°F
A	<b>ALARM PARAMETERS</b>				
A0	Alarm and fan differential	-20.0	20.0	-2.0	°C/°F
AL	Low temperature alarm threshold/deviation (AL= 0; alarm disabled)	-50.0	250.0	-50	°C/°F
AH	High temperature alarm threshold/deviation (AH= 0; alarm disabled)	-50.0	250.0	50	°C/°F
Ad	Low and high temperature alarm delay	0	199	0	min
F	<b>FAN PARAMETERS</b>				
F0	Fan management: 0= fans on excluding specific phases; 1= fans on according to parameter F1 excluding specific phases	0	1	1	-
F1	Fans shutdown temperature	50.0	130.0	2	°C/°F
F2	Fans OFF when compressor OFF	0	1	1	-
F3	Fans status during defrost: 0= fan ON; 1= fan OFF	0	1	1	-
H	<b>OTHER SETTINGS</b>				
H2	Enable keypad 0= keypad disabled 1= keypad enabled 2= keypad enabled except for ON/OFF function	0	2	1	-
EZY	restore the Default settings	0	1	0	-

Tab. 5

## Table of alarms

Alarm code	buzzer and alarm relay	LED	Description	Parameters involved
E0	active	ON	probe 1 error= control	-
E1	inactive	ON	probe 2 error= defrost	[d0 = 0 / 1]
LO	active	ON	low temperature alarm	[AL] [Ad]
HI	active	ON	high temperature alarm	[AH] [Ad]
EE	inactive	ON	unit parameter error	-
EF	inactive	ON	operating parameter error	-
Ed	inactive	ON	defrost ended by timeout	[dP] [dt] [d4] [A8]
dF	inactive	OFF	defrost running	[d6=0]

Tab. 6

## How to restore the Default settings (refer to table of parameters in this sheet)

- Access parameter EZY (entering password 22 and scroll parameter list).
- Select the desired configuration:
  - EZY = 0 → No changes;
  - EZY = 1 → Restore of default settings (refer to Table of parameters in this sheet);
- Exit the setting procedure (holding SET button for more than 3 sec).
- Power off the device and then power it on again while holding SET button.
- The display shows "CE" to indicate that the configuration has been restored.

## Switching the device ON/OFF

Press UP for more than 3 s. The control and defrost algorithms are now disabled and the instrument displays the message "OFF" alternating with the temperature read by the set probe.

## Manual defrost

Press DOWN for more than 3 s (the defrost starts only if the temperature conditions are valid).

## Continuous cycle

Press UP and DOWN together for more than 3 s.

## Technical specifications

power supply	115 Vac +10 / -15% 50/60 Hz 230 Vac -10% +15% 50/60 Hz
rated power	3,5 VA
inputs	NTC probes
relay outputs	16 A relay UL: 12 A Res. 5 FLA 30 LRA - 240 Vac C300, EN60730-1: 12(2) A NO/NC, 10(4) A up to 60 °C NO, 2(2) A CO - 250 Vac 2HP relay UL: 12 A Res. 5 FLA 60 LRA - 240 Vac, EN60730-1: 10(10) A - 250 Vac, 8 A relay UL: 8 A Res. 2 FLA 12 LRA - 240 Vac C300, EN60730-1: 8(4) A NO, 6(4) A NC, 2(2) A CO - 250 Vac
type of probe connections	Std CAREL NTC 10 KΩ at 25 °C Screw terminals for cables with cross-sect. from 0.5 mm2 to 1.5 mm2 Rated maximum current per terminal 12 A
assembly	Terminal: using screws from the front panel or with rear brackets Interface: wall mounting, 4 screws, spacing 101x151 mm
display	3 digit LED display with sign (-199 to 999) and decimal point; six status LEDs
operating conditions	-10T50 °C - humidity <90% rH non-condensing
storage conditions	-20T70 °C - humidity <90% rH non-condensing
range of measurement	-50T90 °C (-58T194 °F) - resolution 0.1 °C/°F
front panel index of protection case	panel installation with IP65 type 1 gasket plastic terminal, 81x36x65 mm
classification according to protection against electric shock	Class II when suitably integrated
environmental pollution	normal
PTI of the insulating material	250 V
period of stress across the insulating parts	long
category of resistance to heat and fire	category D (UL94 - V0)
immunity against voltage surges	category 1
type of action and disconnection	1C relay contacts
no. of relay automatic operating cycles	EN60730-1: 100,000 operations UL: 30,000 operations (250 Vac)
software class and structure	Class A
cleaning the instrument	Only use neutral detergents and water.
cable max. length	serial: 1 km probes: 30 m relay: 10 m

Tab. 7

**Note:** do not run the power cable less than 3 cm from the bottom part of the device or from the probes; **for the connections only use copper wires.**

## Safety standards

compliant with the relevant European standards. Installation precautions:

- the connection cables must guarantee insulation up to 90 °C;
  - ensure a space of at least 10 mm between the case and the nearby conductive parts;
  - digital and analogue input connections less than 30 m away; adopt suitable measures for separating the cables so as to ensure compliance with the immunity standards;
- Secure the connection cables of the outputs so as to avoid contact with very low voltage parts.

## IMPORTANT WARNINGS

The CAREL product is a state-of-the-art device, whose operation is specified in the technical documentation supplied with the product or can be downloaded, even prior to purchase, from the website [www.carel.com](http://www.carel.com). The customer (manufacturer, developer or installer of the final equipment) accepts all liability and risk relating to the configuration of the product in order to reach the expected results in relation to the specific final installation and/or equipment. The failure to complete such phase, which is required/indicated in the user manual, may cause the final product to malfunction; CAREL accepts no liability in such cases. The customer must use the product only in the manner described in the documentation relating to the product. The liability of CAREL in relation to its products is specified in the CAREL general contract conditions, available on the website [www.carel.com](http://www.carel.com) and/or by specific agreements with customers.



**WARNING:** separate as much as possible the probe and digital input signal cables from the cables carrying inductive loads and power cables to avoid possible electromagnetic disturbance. Never run power cables (including the electrical panel wiring) and signal cables in the same conduits.



## Disposal of the product

The appliance (or the product) must be disposed of separately in accordance with the local waste disposal legislation in force.

CAREL reserves the right to modify the features of its products without prior notice.

# CAREL

CAREL INDUSTRIES HQS  
Via dell'Industria, 11 - 35020 Brugine - Padova (Italy)  
Tel. (+39) 0499716611 - Fax (+39) 0499716600 - <http://www.carel.com> - e-mail: [carel@carel.com](mailto:carel@carel.com)

+050004122 - rel. 1.2 - 28.07.2011