

LIQUID LEVEL SENSORS

SELEX™ LIQUID SENSORS

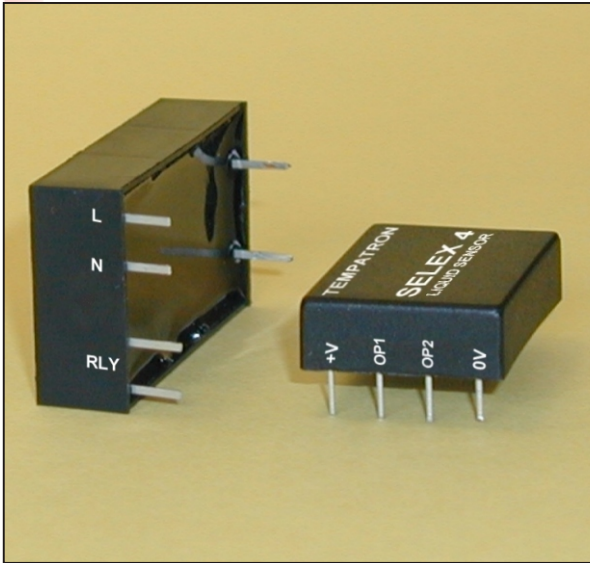

- * Senses liquid presence by detecting free ions
- * High immunity to probe deposits
- * Full galvanic isolation
- * FET output to drive solenoid valve or relay
- * Built in delay to avoid spurious switching
- * Available with 110Vac, 230Vac and 5Vdc supply

The Selex range of printed circuit board mounted sensors provide a low cost solution to the sensing of conductive liquids, particularly in applications where significant deposit build up on the probes can occur, for example with adhesives or systems for use in hard water areas.

These devices use advanced solid state ferromagnetic technology to sense the presence of a liquid by detecting the free ions within it. This novel, low impedance technique passes no measurable current through the liquid and provides full galvanic isolation between the supply and the inputs and outputs.

The Selex range covers high and low voltage operated types. The mains operated versions can be driven from 110 or 230 Vac and have a FET output that can be used to directly drive a solenoid valve or relay to control the liquid flow. It even has an integral 5 second switching delay to avoid problems with sporadic solenoid operation during "liquid slop" conditions. The low voltage version is operated from a 5Vdc supply and has two NPN transistor outputs for high or low level sensing.

The sensor requires two mutually isolated metallic probes, one of which can be the liquid container itself. The optimum surface area of the probes is dependent on the free ion content of the liquid.

SPECIFICATION

Supply voltages : 110Vac, 45-60Hz
 230Vac, 45-60Hz
 5Vdc

Supply variation : +/- 15% of rated voltage

Power drain : 1.75mA nominal

Probe current : <5µA

Output ratings : 110/230V versions : Full wave rectified DC output voltage 99V/207V 20VA max
 5V versions: 2 x 50mA current sink into NPN transistor, open collector, 30Vdc max voltage

Re-activate delay : 5 seconds nominal (110/230V versions only)

De-activate delay : 100 msecs nominal (110/230V versions only)

Probe type : 2 x metallic probes, insulated from tank wall, nominal surface area 1 sq cm

Operation Selex 2 : Relay energised when probe out of liquid
 Selex 3 : Relay energised when probe in liquid
 Selex 4 : Output 1 conducting when probe out of liquid
 Output 2 conducting when probe in liquid

Working temp : -20°C to +65°C

Weight : 13 g (Selex 2 & 3), 7g (Selex 4)

CONNECTION DIAGRAM (pins viewed from below)

SELEX 2 (high liquid level sensing)

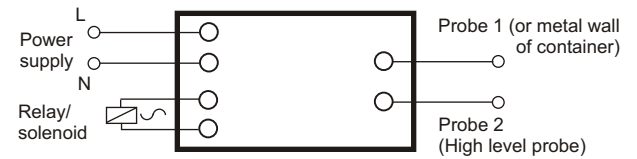

SELEX 3 (low liquid level sensing)

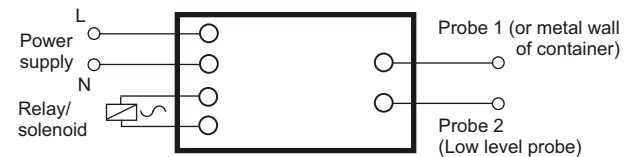

SELEX 4 (high or low liquid level sensing)

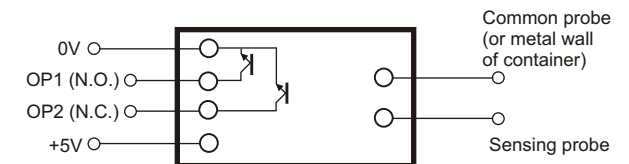

DIMENSIONS

SELEX 2 & 3

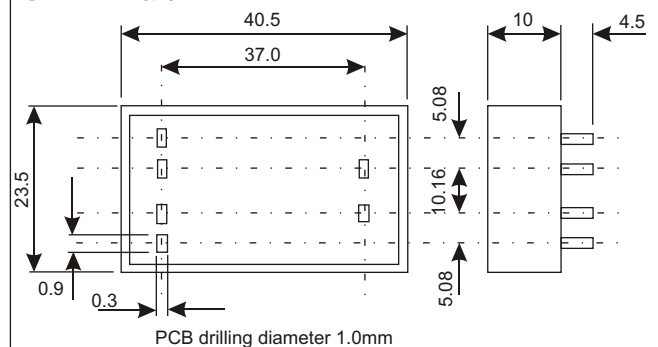

SELEX 4

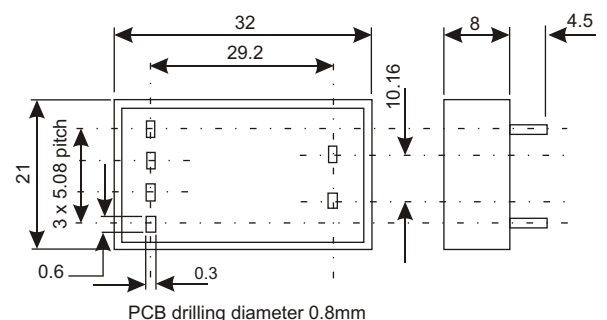

STANDARD ITEMS

Supply Voltage	Output	Sensing	Part Number
110Vac	Relay	High level	SLX2/110R
230Vac	Relay	High level	SLX2/230R
110Vac	Relay	Low level	SLX3/110R
230Vac	Relay	Low level	SLX3/230R
5Vdc	NPN	High & Low	SLX4/005N

Versions with other supply voltages, outputs and anti-slop time delays are available. Contact our sales office for further details

TEMPATRON