

TEMPATRON

IR32 and IRDR Range of Controllers

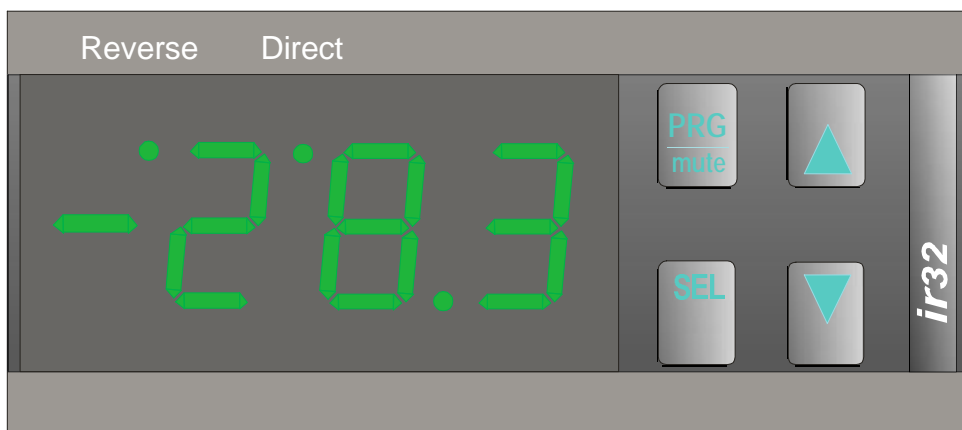

Tempatron Ltd, 5 Darwin Close, Reading, Berks, RG2 0TB.
Tel: 0118 9314062 Fax: 0118 9310175

IR32/DR Industrial Range of Temperature and Process Controllers

The IR32 range of controllers has been developed from the highly successful refrigeration thermostats manufactured by Carel in Italy. These controllers have revolutionised the thinking behind temperature and process control. Current developments in this type of instrument have been based on the assumption that industrial applications require ever increasing sophistication in control techniques, giving tight control and rapid response to the most stringent and variable processes.

However, the vast majority of applications do not require such complicated and sophisticated techniques. This is not to say that the IR32/DR is not sophisticated; programmable alarm functions, control action, time delays, output sequencing,selectable setpoints, Infra-red remote control and many other features justify such a description for this range of products. The point is that the basic control actions of On/Off and Proportional+Integral are quite sufficient to provide stable control for many applications, with the significant benefit of a price tag of better than 50% of the now common PID, autotuned controllers supplied elsewhere.

Another revolutionary concept incorporated in the IR32/DR range is the pre-determined and selectable control actions (Function Modes). Here the user can decide which Control action suits his application, for example; Heat+Cool with Deadband, Direct action plus Alarm or PI mode with selectable setpoints. Simply by selecting 1 of the 9 preset modes, he can dedicate the operation of the IR32/DR to a specific function.

Finally, for applications which require multiple controllers, such as supermarkets or building ventilation, it is possible to program the IR32/DR from either a remote, infra-red, hand-held programmer or a PC, via a RS485 communications network.

Key Features

- . 9 pre-determined and selectable Function Modes
- . 1, 2 or 4 output options incorporated in a single housing
- . 1 or 2 setpoints, selectable by a remote digital input
- . Direct, Reverse or Heat + Cool + Deadband control action
- . Programmable Alarm action, hysteresis and time delays
- . Programmable Control cycle and delay times
- . On/Off. Proportional or PI control Modes
- . Infra-red remote programming
- . RS232/485 communications option
- . Autoranging, three digit display with decimal point resolution
- . Output rotation on 2 or 4 output models, for load protection and optimal wear
- . IP65 water and dust protection(IR32 only)
- . 12-24Vac/dc and 24-240Vac (IR32V only) supply options
- . CE emc and low voltage compatibility

Part Number System

IR 32 V 1 E 000

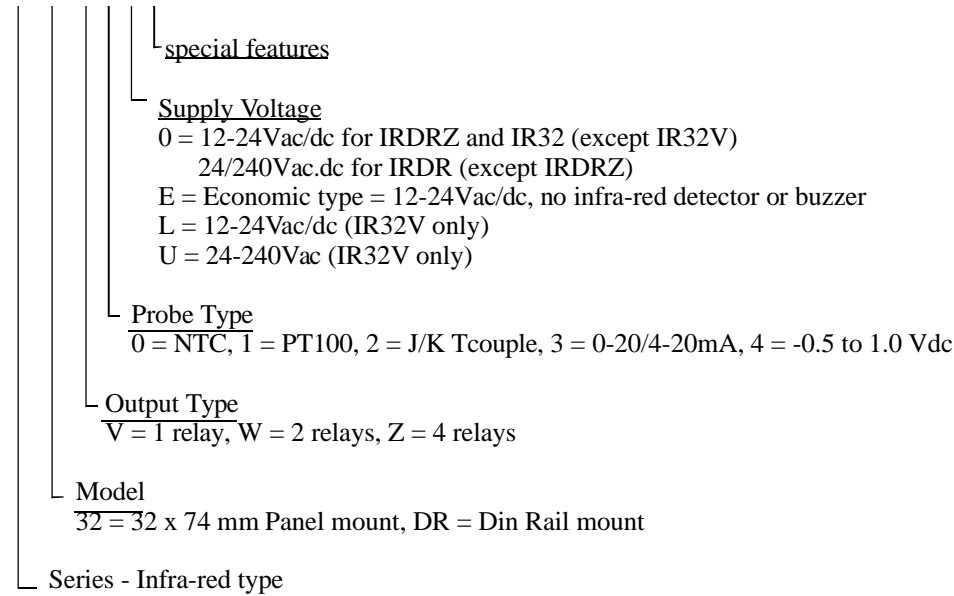

Front Panel Functions

**PROG
MUTE**

- : When momentarily pressed, enters all new parameters selected from other keys.
- When pressed for > 5 secs, accesses primary parameters.
- When pressed simultaneously with **SEL** key, accesses Function Modes , via code 22.
- When pressed simultaneously with **SEL** key, accesses Advanced Parameters, via code 77.
- Cancels alarm buzzer when activated. Note: this does not reset the alarm conditions.

SEL

- : When momentarily pressed, accesses Set-Point.
- When pressed simultaneously with **PROG** key, accesses Function Modes and Advanced Parameters.
- Once a parameter has been accessed, enables variable adjustment via and keys, and acknowledgement of new value.



- : Allow forward or reverse rotation through program parameters and up or down adjustment of variables.

O Reverse : Reverse Action Led. Flashes cyclically for each output activated in Reverse Mode.

O Direct : Direct Action Led. Flashes cyclically for each output activated in Direct Mode.

888 : 3 digit, green Led display. Displays Process Value, Alarm Codes, Set-Point, parameter codes and parameter values, when in program mode.

Function Modes	
Mode No.	Function
1	Direct action mode with adjustable Set-Point (SP) and differential (Hysteresis) above SP.
2	Reverse action mode with adjustable Set-Point (SP) and Hystereris below SP.
3	Reverse action mode with adjustable SP, Hysteresis and Dead-Band (DB). For 2 (W) and 4 (Z) output models, DB is equi-spaced about SP.
4	Proportional (P) action mode with adjustable SP, proportional Band (PB) and DB. As for Mode 3, DB is equi-spaced around SP for W and Z models. A Proportional + Intergral (PI) mode is also available by selecting the correct variable in parameter C5.
5	Alarm Mode, operating as for Mode 3 but with one output dedicated as an alarm signal. For single output (V) models the output is an Alarm, for W models one output is dedicated to a high/low alarm and, for Z models, two outputs are dedicated to high and low alarms respectively.
6	Direct or Reverse action mode, selectable from the digital input (DI). DI open = Direct DI closed = Reverse.
7	Direct action mode with two Set-Points SP1 and SP2, each with its own adjustable Hysteresis and selectable from the digital input. DI open = SP1/HY1 and DI closed = SP2/HY2.
8	Reverse action mode with functions as for Mode 7.
9	Direct plus Reverse action mode (Heat + Cool) with each dedicated to one output (2 for Z models) providing two independant Set-Points. This mode is only available for W and Z models.

Error Messages

Message	Description	Cause	Solution
Er0	Probe error	Open or short circuit probe or connection.	Check connections and probe.
Er1(NTC2)	Probe error	As for Er0.	As for Er0.
Er2	Memory error	Supply disconnected during programming. Electrical noise.	Turn off, then on holding down SEL Replace unit, if persistant.
Er3	External Alarm	Digital Input contact open.	See C29, check external contacts.
Er4	High Alarm	Input has exceeded P26 for > P28 period	Check parameters P26 and P28.
Er5	Low Alarm	Input is below P25 for > P28 period	Check parameters P25 and P28

Note: Press **PROG/MUTE** to silence alarm buzzer but check appropriate parameters to reset outputs.

Parameter Table

Code	Function	Default Value	Range	Parameter Access		
				Prim	FM	Adv
St1	Set-Point 1	20	see spec.			
St2	Set-Point 2 (Function Modes 6, 7, 8, 9)	40	see spec.			
C0	Function Mode	2	1 to 9		X	X
P1	Hysteresis of SP1	2	0.1 to 99.9	X	X	X
P2	Hysteresis of SP2 (Function Modes 3, 4, 5, 7, 8, 9)	2	0.1 to 99.9	X	X	X
P3	Dead-Band (Function Modes 3, 4, 5)	2	0 to 99.9	X	X	X
C4	Compensation Coefficient - NTC only (see operation manual)	0.5	-2.0 to 2.0			X
C5	Control action in Function Mode 4. 0 = Prop (P), 1 = Prop + Integ (PI)	0	0 or 1			X
C6	Delay between on routines of two different outputs	5	0 to 999 secs			X
C7	Minimum time between on routines of the same output	0	0 to 15 mins			X
C8	Minimum off time of the same output	0	0 to 15 mins			X
C9	Minimum on time of the same output	0	0 to 15 mins			X
C10	Status of outputs with probe(temperature) alarm : 0 = all relays de-energised 1 = all relays energised 2 = Direct action relays energised, all others de-energised 3 = Reverse action relays energised, all others de-energised	0	0 to 3			X
C11	Output rotation (Function Modes 1, 2, 6, 7, 8 and Models W & Z only) 0 = no rotation 1 = rotation of 2 out of 4 outputs (model Z only) 2 = 2 + 2 rotation (Compressor on outputs 1 & 3, model Z only) 3 = 2 + 2 DWM rotation (model Z only)	0	0 to 3			X
C12	Cycle Time of proportional modes (P and PI)	20	0.2 to 999 secs			X
C13	Probe type: 0 = 4 - 20mA, 1 = 0 - 20mA or 0 = K T/c, 1 = J T/c	0	0 or 1			X
P14	Probe calibration or offset	0	-99 to 99.9	X	X	X
C15	Minimum value for scaling of analogue inputs	0	-99 to C16			X
C16	Maximum value for scaling of analogue inputs	100	C15 to 999			X
C17	Probe response time (noise filter)	5	1 to 14			X
C18	Temperature units: 0 = o C, 1 = o F	0	0 or 1			X
C19	Ambient compensation of 2nd probe - NTC only (see operation manual)	0	1 to 4			X
C21	Minimum Set-Point (SP1) limit (depends on probe type)	min probe	-99 to C22			X
C22	Maximum Set-Point (SP1) limit (depends on probe type)	max probe	C21 to 999			X
C23	Minimum Set-Point (SP2) limit (depends on probe type)	min probe	-99 to C24			X
C24	Maximum Set-Point (SP2) limit (depends on probe type)	max probe	C23 to 999			X
P25	Low absolute alarm set-point	min probe	-99 to P26	X	X	X
P26	High absolute alarm set-point	max probe	P25 to 999	X	X	X
P27	Alarm hysteresis	2	0.1 to 99.0	X	X	X
P28	Alarm delay	60	0 to 120 mins	X	X	X
C29	Alarm relay status with Digital Input (DI) (C0 = 5 only): 0 = Non active input 1 = Immediate alarm - all relays de-energise, automatic reset on clear 2 = Immediate alarm - all relays de-energise, manual reset(mute) on clear 3 = delayed alarm (P28) - all relays de-energise, manual reset(mute) on clear 4 = All alarm relays inactive with DI open (-- --) flashes Note: Whenever DI opens Er3 message occurs & buzzer sounds.	0	0 to 4			X
C30	Digital input 2 (IRDR models only). Options as for C29	0	0 to 4			X
C31	Status of output relays with Digital input (see C10)	0	0 to 3			X
C32	Address of unit for serial comms. connection	1	1 to 16			X
C33	Do not modify this parameter	0	0 or 1			X
C50	Activation of Keypad (KP) and Remote Control Unit (RC) : 0 = KP off, RC on (code 22) 1 = KP on, RC on (code 22) 2 = KP off, RC off 3 = KP on, RC off 4 = KP off, RC on (code 77)	0	0 to 4			X
C51	Code to activate Remote Control Unit	0	120			X

Note: Prim = Primary functions, FM = Function Modes, Adv = Advanced functions

Program Parameter Map

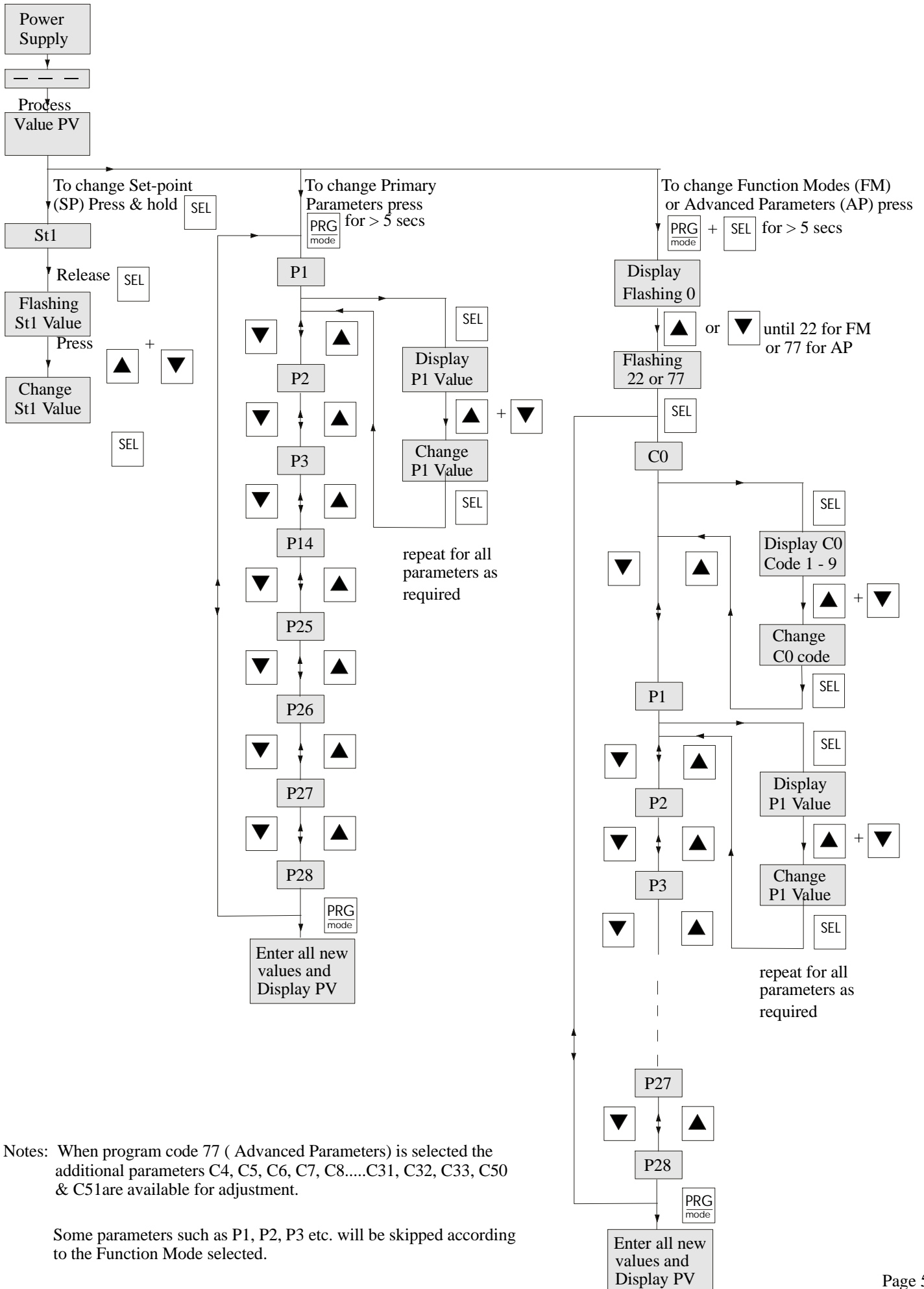

Notes: When program code 77 (Advanced Parameters) is selected the additional parameters C4, C5, C6, C7, C8.....C31, C32, C33, C50 & C51 are available for adjustment.

Some parameters such as P1, P2, P3 etc. will be skipped according to the Function Mode selected.

Technical Specification

Input Options:	NTC, PT100, J or K TCouple, 0 - 20mA, 4 - 20mA, -0.5 to 1.0 Vdc according to model (see part number).
Operating range:	NTC: -50 to +90 °C PT100: -99 to +600 °C J T/c: -99 to +800 °C K T/c: -99 to +999 °C mA/V: -99 to 999 scaleable
Resolution:	0.1 or 1 unit, according to displayed value (autoranging)
Accuracy:	+/- 0.5% of max. range
Supply Voltage:	See Part Numbering system. All values are +/- 10%.
Power Consumption:	3VA max.
Probe supply:	10Vdc @ 30mA max. supplied by controller.
Working Temperature:	0 to 50 °C
Storage Temperature:	-10 to 70 °C
Relative Humidity:	90% rH max, non-condensing.
Output Configuration:	IR32 for NTC: 1,2, or 4 SPDT relays IR32V: 1 SPDT relay IR32W: 1 SPST + 1 SPDT relays IR32Z: 1 SPST + 3 SPDT relays IRDR (except Z): 1 or 2 SPDT relays IRDRZ: 2 SPDT + 2 SPST relays
Relay Ratings:	Relays: 8A/250Vac max with 2000VA max switching power (10Amps inrush) SSR's: 8Vdc open-circuit, 4Vdc @ 8mA
Protection Index:	IR32: IP65, IRDR: IP40
Fire Retardancy:	Plastic case and relays: ECC EN 60730-1
EC Compatibility:	Comply to Directive 89/336/EEC(modified to 92/31/EEC) and are designed to meet the EN60555-2 standards on emissions and EN50082-1 standards on immunity. These products may be assembled to machinery covered by Directive 89/392/EEC and meet the low voltage Directive 73/23/EEC

Dimensions

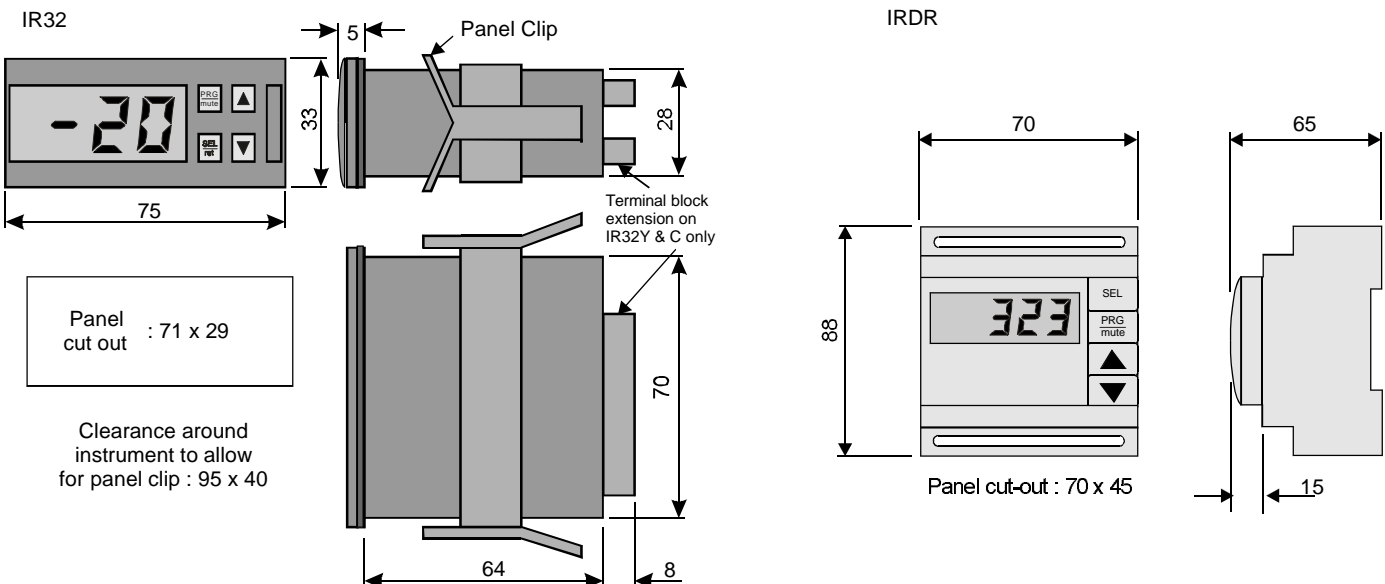

Connection Diagrams

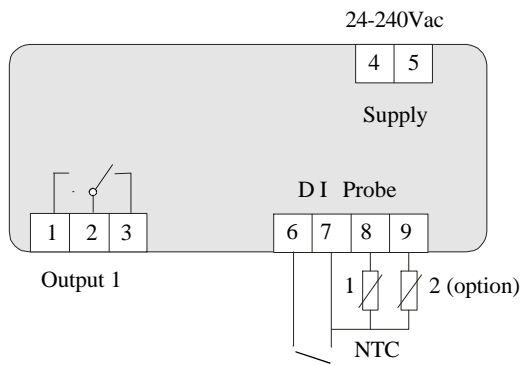

**IR32 Models
NTC only**

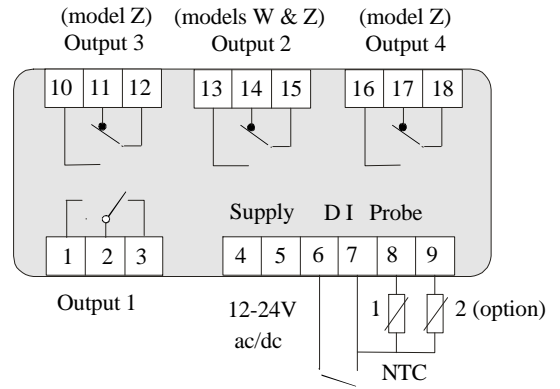

**IR32 Models
All other
Probe types**

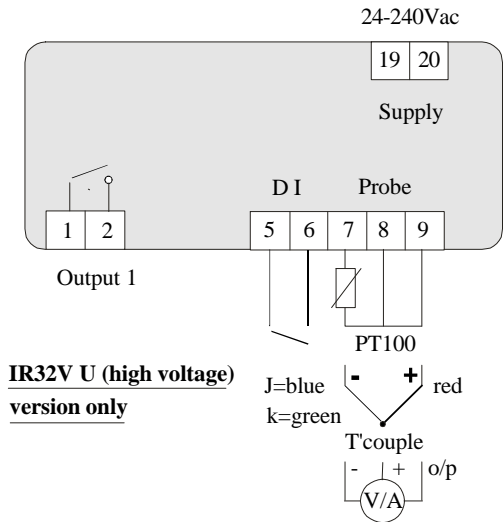

**IR32V U (high voltage)
version only**

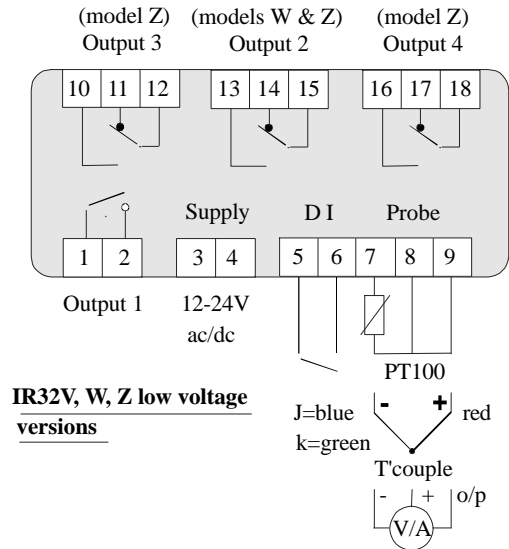

**IR32V, W, Z low voltage
versions**

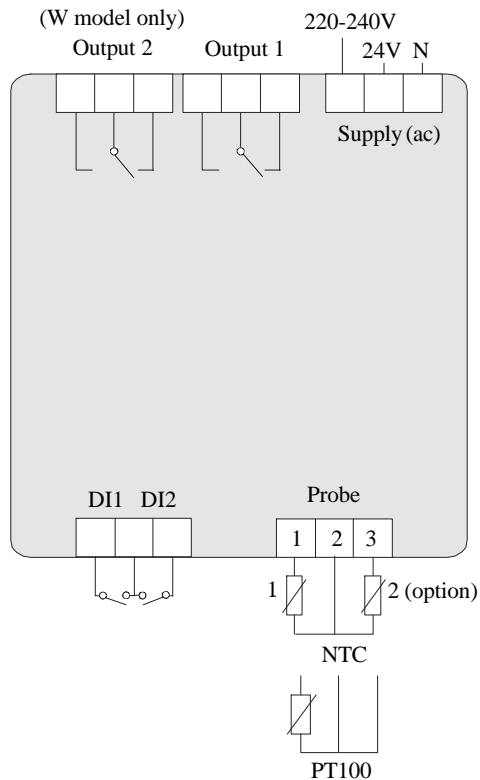

IRDRV & W
NB: IRDRTE does not have 24V supply

IRDR Models

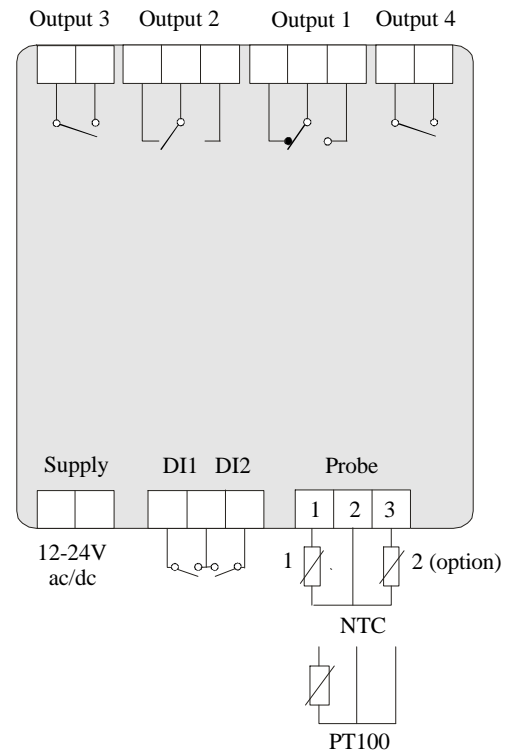

IR32Z

